

# *Direct Vent Kit's for BLASI Boilers*

**DVF-4 Vent Kit**



**DVH-5 Vent Kit**



**Passive Direct Vent Systems-Oil or Gas**

**Removable air intake snout – for ease of installation**

**Continuous exhaust pipe – eliminates chance for cross contamination**

**Concealed air intake – reduces risk of exhaust recirculation**

**Lightweight**

# Side Wall Pipe Kit's for BIASI Boilers

## Rigid Pipe Side Wall Direct Vent Kit

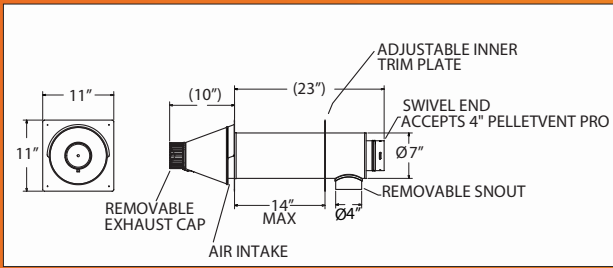

\*\*Accommodates wall thicknesses up to 14"\*\*\*

DuraVent's Oil Vent Pro is a professionally engineered, easy to install direct vent system for oil or gas B10 and SG Boilers. It features a smooth interior to reduce whistling and friction loss and utilizes a quick connect / release twist-lock design on the vent pipe that requires no tools. No sealant is needed on the vent pipe joints. Adjustable vent pieces allow easy installation so you always get your final lengths without cutting. The concentric termination is designed with a removable end-snout for easy servicing and installation. The strong outer wall prevents damage and denting. All direct vent systems should be installed on the leeward side of the house.

Gas / Oil Vent Kit	Boiler	QHT ORDER#
DVF -4 RIGID	B10 -3,4,5,6; SG -3,4	DVF -4

Kit includes: 6" to 4" adapter, 2 4" elbows, 4" x 36" rigid length, 4" x 24" rigid length, 3" to 16" pipe extension, 4" concentric termination, 4" x 10' Aluminum intake flex duct, 4" tee, 4" 90, 4" vacuum relief, L4006A safety high limit, 3/4" immersion well, 1 1/2" x 3/4" x 1 1/2" tee

This kit provides approximately 10 feet of equivalent length. This kit can be extended to 20 feet of equivalent length.

## Flexible Pipe Side Wall Direct Vent Kit

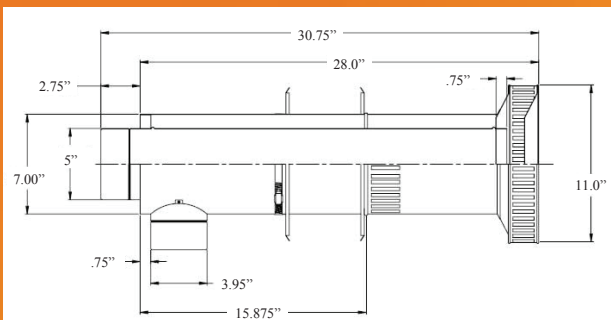

\*\*Accommodates wall thicknesses up to 10"\*\*\*

The Z-Flex Direct Vent Kit is a professionally engineered, easy to install vent system for oil B10 and SG Boilers. It features a flexible vent pipe allowing easy installation with no pipe joints. The concentric termination is designed with a round diffuser that helps disperse the exhaust gases away from the intake side of the pipe to reduce the risk of any cross contamination. The strong outer wall prevents damage and denting. All direct vent systems should be installed on the leeward side of the house.

Oil Only Vent Kit	Boiler	QHT ORDER#
DVH -5 FLEXIBLE KIT	B10 -3,4,5,6; SG -3,4	DVH -5 COMBO

Kit includes: 6" to 5" adapter, 6" elbow, 5" elbow, 5" x 8' double wall flex pipe, 5" double wall adapter, 5" concentric termination, 5" x 2' insulation sleeve, 4" x 8' Aluminum intake flex duct, 4" tee, 4" 90, 4" vacuum relief, L4006A safety high limit, 3/4" immersion well, 1 1/2" x 3/4" x 1 1/2" tee.

This kit provides approximately 10 feet of total exhaust length. THIS KIT CANNOT BE EXTENDED.

800-501-7697  
www.biasiboilers.us



Quincy Hydronic Technology, 02/2017